



Eclipse 120Wp

20 cell

Framed - Bifacial - Transparency 70%



Fire class A



Extreme load resistance

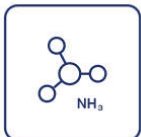

Ammonia resistance

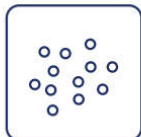

Salt mist resistance



98,8% recyclable



Hail resistance class 3



35% of recycled glass content

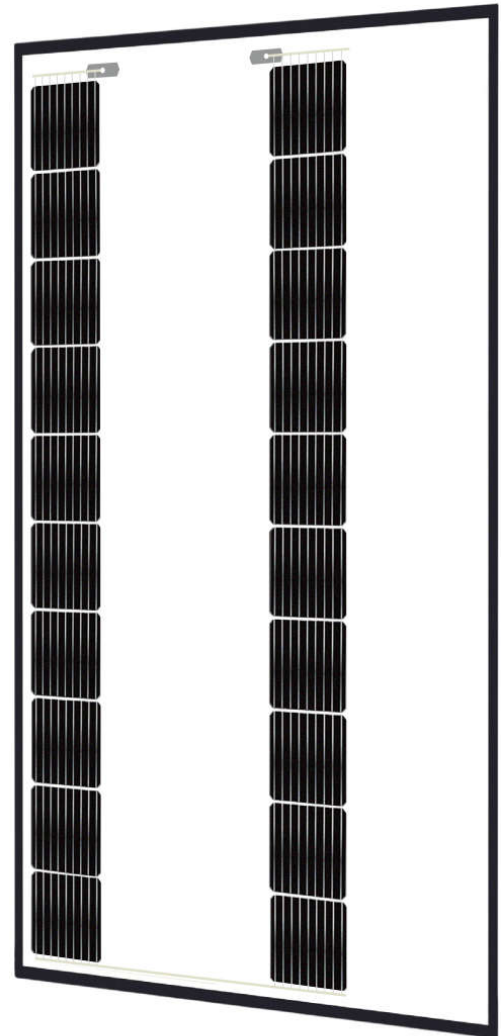

Positive sorting up to +5W

Front side ⚡ 120 W

Deutsches Institut für Bautechnik

DIBt

DIBt In Progress



30 Year product warranty

87% Power warranty

30 Year efficiency warranty

Electrical data (STC*)	
Maximum power (W)	120
Cell technology	Bifacial
Open circuit voltage (V_{oc}/V)	13,50
Short circuit current (I_{sc}/A)	11,18
Max power voltage (V_{mpp}/V)	11,30
Max power current (I_{mpp}/A)	10,62
Module efficiency (η)	6,34%
Max system voltage (V)	1000
Max current (A)	20
Power tolerance	0/+5W

*Under standard test conditions (STC) of irradiance of 1000W/sq.m., spectrum AM1.5 and cell temperature of 25°C. Flash testing measurement accuracy of +/-5%.

Warranty	
30 years product warranty	
30 years efficiency warranty	
First year degradation (%)	2 %
Annual degradation (%)	0.379 %
Power in year 30 (%)	87 %

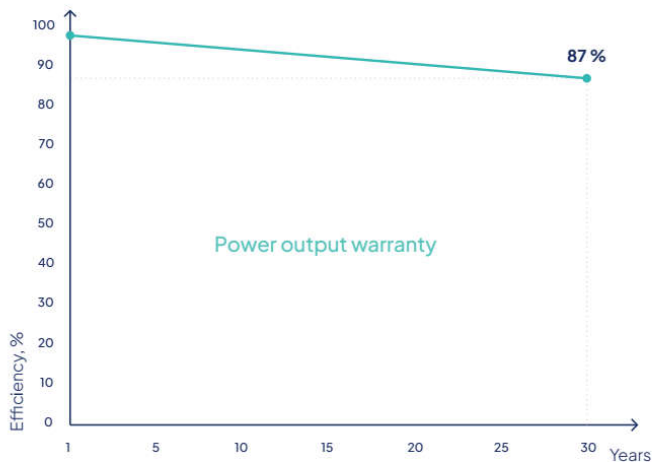
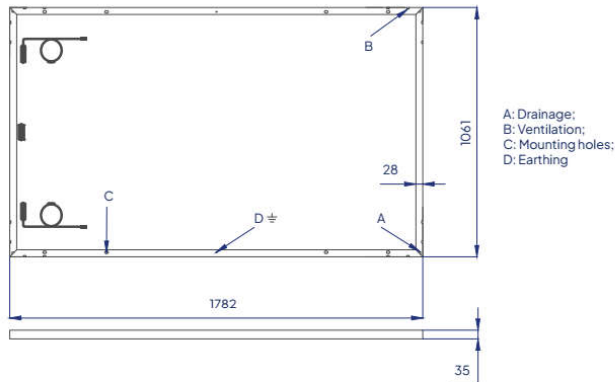

Temperature ratings	
Current temperature coefficient (α)	+0.036% / °C
Voltage temperature coefficient (β)	-0.265% / °C
Power temperature coefficient (δ)	-0.362% / °C
Nominal operating module temperature	46 °C
Mechanical data	
Dimensions (LxWxH) (mm)	1782x1061x35 mm
Weight (kg)	24
Front glass (mm)	2
Back glass (mm)	2, transparent
Cell Size (mm)	166x166
Busbars	9
Transparency %	70
Cell configuration	2x10
Frame	Black anodized aluminium frame
Rated operating altitude	Up to 2000 m
Operating temperature (°C)	-40 ÷ +85
Maximum test load (wind/snow) (Pa)	3600/8100
Junction box / IP class	Split junction box / IP68
Cable cross section size (mm ²)	4
Cable length	1,2 m
Bypass diodes	3
Connector	MC4 compatible

Packing information	
Modules per pallet	30 pcs
Dimensions of a pallet (LxWxH)	1840x1140x1280 mm
Weight of a pallet (gross)	782 kg
Pallets per 13.6 m truck	28 pcs
Modules per 13.6 m truck	840 pcs

Certifications	
IEC 61215:2021; IEC 61730:2016; UL 61730:2017	
Cradle to Cradle (C2C)	Gold level
IEC 62716:2013	Ammonia corrosion testing
IEC 61701:2020	Salt mist corrosion testing
IEC 61215-2:2021	29mm hailstone – Hail resistance class 3 (HW3)
ISO 9001:2015	Quality management systems
ISO 14001:2015	Environmental management systems
ISO 45001:2018	Occupational health and safety
SundaHus	A level assessment
Produced using 100% renewable energy	
Membership at Svensk Solenergi	

